

VIL410, CPI EDB'S 1.3 GHZ, 25 KW CW IOT AMPLIFIER SYSTEM

I. Elkin, R. Army, P. Brown, S. Locke, R. Rizzo, R. Snyder, G. Solomon, M. Tracy, T. Treado[#],
CPI Electron Device Business, Inc, Beverly, MA 01915, USA

Abstract

The VIL410 Heatwave™ Inductive Output Tube (IOT) amplifier system has been developed to meet the requirements of superconducting RF accelerators. Two VIL410 systems were completed and delivered in April 2014. The VKL9130A1 IOT in the VIL410 provides up to 30 kW RF output power over a 5 MHz bandwidth centered at 1.30 GHz. It operates both CW and pulsed. The VIL410 amplifier has been designed to achieve very tight amplitude and phase control. The amplitude and phase ripple are specified to be less than 0.1% rms and better than 0.2° rms, respectively. The stability of the output power is specified to be better than 0.2% over a 20 second period. In normal system operation, smooth control of the output power is accomplished via input from the low level RF system. The VIL410 uses CPI EDB's VSL3616 Solid State Power Amplifier (SSPA) to drive the IOT. The VSL3616 is a 700 watt CW SSPA that operates at 250 watts CW in the VIL410. The VIL410 has an embedded processor that controls all internal functions of the amplifier system and interfaces directly to EPICS. The VIL410 can be operated locally using a LabView™ PC Host program or remotely by EPICS.



Figure 1: VIL410 IOT amplifier.

RF REQUIREMENTS

In order to operate into super conducting cavities, the VIL410 (Figure 1) must be protected by a four-port waveguide circulator. The circulator protects the amplifier from high reflected RF power. The circulator is equipped with water loads that can absorb the full output power, allowing the amplifier to operate into an RF short of any phase without damage or fault shutdown. The circulator, manufactured by Ferrite Microwaves Technologies, LLC, was provided as part of the VIL410 system.

The VIL410 meets the specifications listed in Table 1.

[#]todd treado

Table 1: Specifications

Parameter	Specification
Frequency	1300 MHz
3 dB Bandwidth	5 MHz
Gain	≥ 72 dB
Output Power	≥ 25 kW
Input Power	≤ 1 mW
Phase Variation	≤ ±8°
Gain Variation	≤ 2 dB
Amplitude Ripple	< 0.1 % RMS
Phase Ripple	≤ 0.2° RMS
Power Stability	< 0.2 % in 20 sec Interval

RF CHAIN

The RF chain consists of an SSPA (VSL3616) driving an IOT (VKL9130A1) and then finally a four-port WR650 differential phase-shift circulator. The SSPA provides 250 W of drive power to the IOT with 62 dB gain – typical input drive is -9 dBm. The IOT gain at 25 kW output power is 22 dB. The insertion loss of the circulator is 0.4 dB at full power. The overall system gain is 83.6 dB.

VSL3616 SSPA

The SSPA consists of a three-stage driver amplifier assembly driving a two-way in-phase power splitter. The output from the splitter drives a pair of two-stage power sections consisting of a 40 W stage driving a pair of 200 W unmatched power transistors operating in a balanced configuration.

RF from the two pair of output devices is combined using a four-way Gysel power combiner that has low insertion loss and high port-to-port isolation. The combined output provides up to 750W of RF power into a ferrite isolator that protects the SSPA from reflected power. The output of the isolator drives a dual directional coupler with a rear panel 7/16 DIN connector. The coupled outputs are used for forward and reverse power monitoring.

The entire system including the DC power supplies is mounted to a water cooled plate to draw heat from the major assemblies. The system is contained in a 19 inch rack which is 4 units high and 26 inches deep. The unit is powered by 240 Vac and requires approximately 1900 W of power at full RF output. The VSL3616 SSPA is described in detail in [1].

VKL9130A1 IOT

Shown in Figure 2, the CPI EDB VKL9130A1 selected for this transmitter achieves an output power of 30 kW CW

and can be operated CW or in pulsed mode. The IOT is a hybrid vacuum electron device incorporating a power-grid-triode input with an inductive, klystron-type output. Its beam is RF modulated by a gridded gun that biases the beam so that the amplifier can be adjusted for differing classes of operation. An IOT-based amplifier has the advantage of possessing smaller foot print, lower capital cost, and enhanced power efficiencies when compared with 30-kW solid-state or klystron-based amplifiers.



Figure 2: VKL9130A1 IOT.

RF PERFORMANCE

Gain and phase pushing as a function of output power are shown in Figure 3 for the VIL410. For output power between 5 and 25 kW, the gain and phase are well-behaved. RF output power and efficiency are shown in Figure 4 as a function of input RF power. The efficiency of the VIL410 is 40% at 25 kW.

The bandwidth of the VIL410 system is determined by the IOT amplifier and measured data is shown in Figure 5. It can be seen that the system meets a ± 2.5 MHz requirement.

RMS amplitude and phase ripple were measured in a 100 mS window using 120 kHz bandwidth. The measured amplitude ripple was 0.1% RMS, and the phase ripple was 0.05° RMS. The bridge configuration shown in Figure 6 was used to make these measurements. RMS ripple values, both phase and amplitude, were calculated from mixer I and Q waveforms that were digitized using a 12-bit sampling oscilloscope.

Power stability was measured in a 20 second window. Because our cooling water regulator might cycle during the data acquisition, the stability numbers varied between measurements but were typically about 0.13%.

The measured phase sensitivity to coolant water

temperature is $0.58^{\circ}/^{\circ}\text{C}$, and the power sensitivity is $-0.07\text{dB}/^{\circ}\text{C}$.

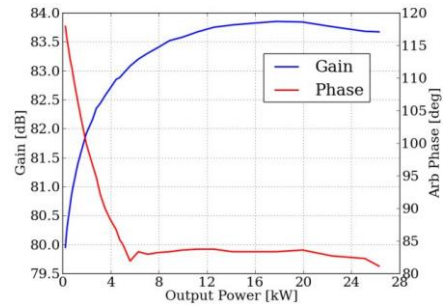

Figure 3: Gain and phase vs. output power.

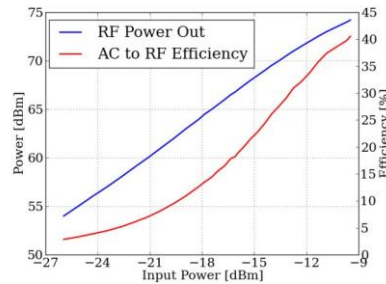

Figure 4: Output power and efficiency vs. input RF power.

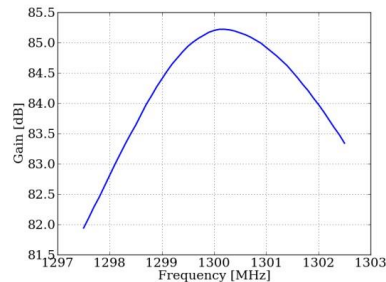

Figure 5: Gain vs. frequ

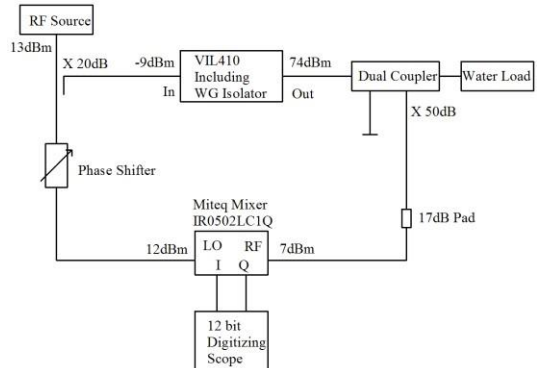

Figure 6: Measuring phase and amplitude ripple.

Copyright © 2014 CC-BY-3.0 and by the respective authors

Pulsed Operation

Although the VIL410 system was designed for CW operation, it can be operated in pulsed mode by applying a pulsed RF input signal [2]. In pulsed operation the peak power is still 25 kW and any pulse width greater than 100 ms is supported. Figure 7 shows a detected RF pulse 100 ms wide (top). Because the HV and grid power supplies are already on, the RF rise and fall time are only 120 ns, when measured from 10 to 90% (bottom).

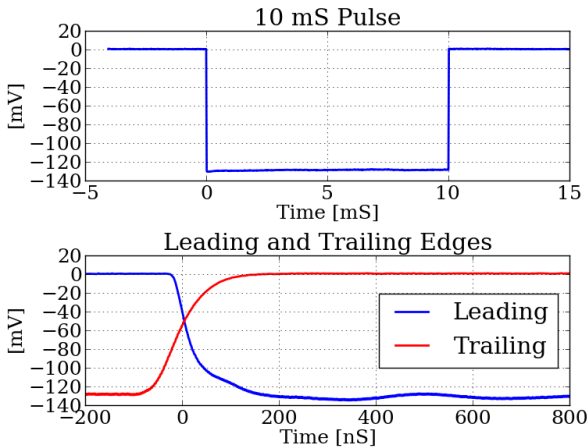

Figure 7: Pulse mode detected output RF.

CABINET LAYOUT

The VIL410 occupies three standard rack mount cabinets. The first cabinet houses two high voltage DC power supplies and a controller that synchronizes the outputs to achieve high regulation and low ripple. Also in this bay are the embedded industrial controller and fast fault control electronics. Additionally auxiliary power supplies and three-phase AC line power distribution is accomplished in this bay.

The middle cabinet is the HV bay. The floating grid deck power supply, stored energy capacitor, arc protection, and current sensing circuitry are mounted here.

The third cabinet is the RF bay. The VSL3616 SSPA and the VKL9130A1 IOT are mounted in this bay, together with a dual directional waveguide coupler.

The WR650 waveguide circulator is located outside the amplifier cabinet. See Figure 8 for component locations.

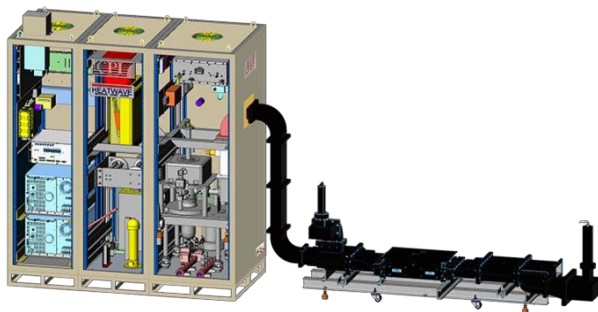

Figure 8: VIL410 cabinet layout and circulator.

AC POWER AND WATER COOLING

The AC prime power requirement for the VIL410 is 380 Vac, 50/60 Hz, 130 kVA, Y (3 phase plus neutral and ground). At an RF output power of 26.3kW, the AC line current is about 100 A per leg. Figure 9 shows AC prime power as a function of RF output power. The required cooling water flow is 18 GPM.

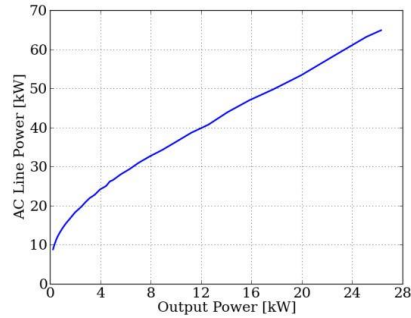

Figure 9: AC line power vs. output power.

CONTRIBUTORS TO RF STABILITY

The greatest technical challenge was meeting the RF stability requirements. For 30 kW RF output, Table 2 shows estimated IOT phase and amplitude sensitivities for RF drive, grid voltage, and cathode voltage. Some general observations:

- Grid voltage exerts the greatest influence on phase and amplitude stability.
- Meeting the amplitude stability specification guarantees meeting the phase stability specification.
- RF drive from the SSPA takes the bulk of the total amplitude and phase stability budget. Because the gain of the SSPA is much higher than that of the IOT, RF stability of the SSPA dominates in the system stability budget.

Table 2: IOT RF Sensitivities at 30 kW

Parameter	Amplitude	Phase
RF Drive	158 Pout/Pin	0.06°/W
Grid Voltage	300 W/V	1.7°/W
Cathode Voltage	2.1 W/V	0.5°/kV

CONCLUSION

CPI Electron Device Business has successfully delivered two VIL410 systems for use in a superconducting accelerator application.

REFERENCES

[1] G. Solomon et al., “The VSL3616, CPI EDB’S 1.3 GHz, 700 Watt CW, GaN Solid State Power Amplifier, WEPME022, *these proceedings*, Proc. IPAC14, Dresden, Germany (2014).
 [2] M. Marks et al., THPEB061, p. 4011, Proc. IPAC10, Kyoto, Japan (2010); <http://jacow.org>